

LAB
WAVE

Operating Instructions



Fully Automatic Cell Counter

CC-0001



Disclaimer

To ensure the safe and reliable operation of the Auto Cytometer (hereafter referred to as Instrument), please read and follow the instructions in this manual. This instrument is intended for research testing only, not for medical device. The company bears no responsibility or obligation for any damage or loss caused by improper operation and usage as per the instructions.

Operating Environment

1. Place the instrument on a dry, sturdy, and stable table.
2. Prevent moisture: keep the instrument away from dust and smoke, and avoid direct sunlight.
3. Operating temperature should be within the range of 4°C to 40°C.
4. Prevent dust and particles from entering the instrument; store reagents and cell counting plates in a dust-free environment to avoid affecting image quality.

Waste Disposal

Dispose of tissue or cell waste materials such as cell counting plates and pipette tips following the relevant biohazardous material disposal regulations.

Announcements

1. Connect the instrument to a grounded power source.
2. Operators must be trained and operate this instrument within a well-managed laboratory. Wear protective clothing, especially gloves, when handling samples.
3. Handle reagents like Trypan Blue, AO/PI dyes, etc., following relevant safety rules.
4. This instrument must be used together with counting plates of the matching specifications. Only uncontaminated, clean, and sterile samples can ensure the optimal operation of this instrument.
5. After using the instrument, please promptly turn off the power.
6. It is forbidden to open the instrument in low temperature environment. If the instrument is accidentally placed in low temperature environment, please transfer the instrument to room temperature and rest for at least 2h.
7. This instrument is forbidden to be placed on the vibration test table. Please ensure the stability and level of the test table.

Hardware

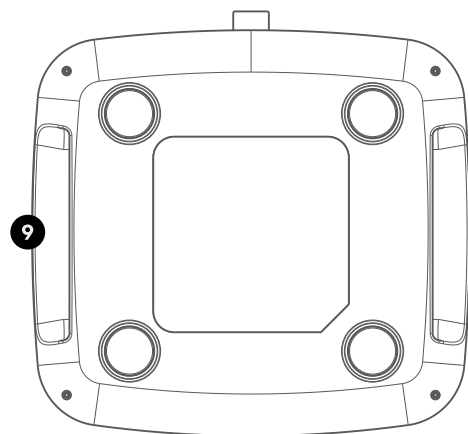
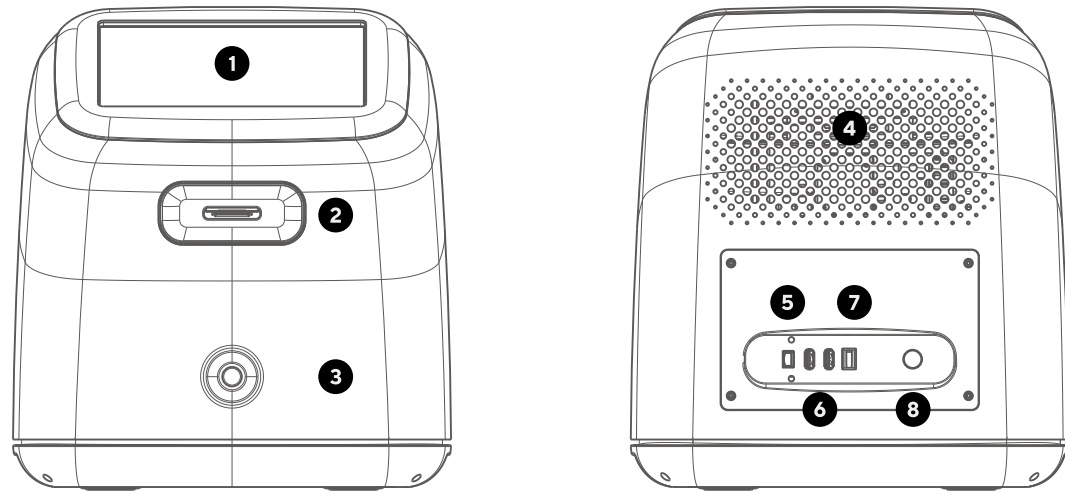

1. Dscreen
2. Sample Port
3. Main Switch
4. Device Vent
5. Network Port
6. 2 USB Ports
7. Power Switch
8. Power Socket
9. Handling Bracket

Software

This instrument comes with pre-installed operating software, including login interface, experiment interface, data interface, and settings interface, etc. Customized software solutions complying with FDA 21 CFR Part 11 (CC-0001 only) are also available.

Operation Instructions

1. Start-up

Figure 1: Unpack the box, take out the instrument. Use the Allen wrench from the accessories to remove the transport fastening bolts at the bottom of the instrument to deactivate the transport protection mode.

Figure 2: Take out the medical power supply and power cord from the accessories, connect them to the power source and the instrument. Press the power switch at the back of the device to the "on" position.

Figure 3: Press the main switch on the front, the indicator light turns blue, and the display screen lights up.

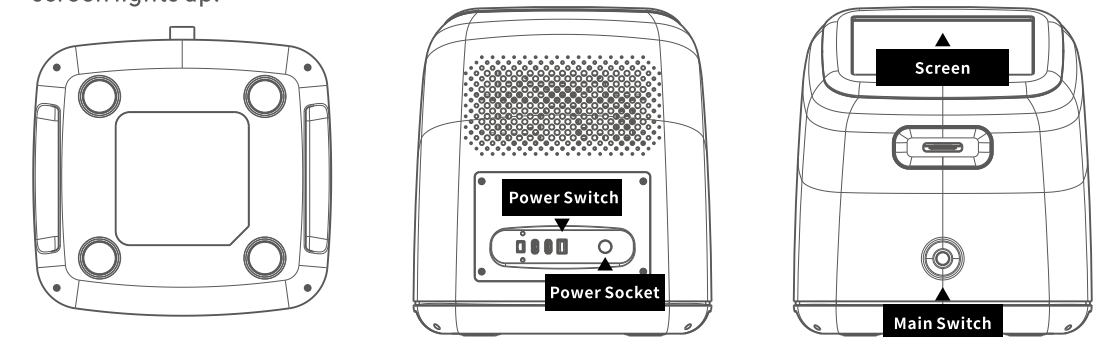

Figure 1
Bottom

Figure 2
Back

Figure 3
Front

⚠️ Reminder: To prevent damage during transportation, this device is designed with a transport protection mode. Once the transport protection mode is deactivated, please keep the transport fastening bolts and the Allen wrench from the accessories for future transportation use.

2. Login

Figure 4: After the software starts, enter the username and password in the software login interface, then click login.

Initial Username: admin, Initial Password: 123456.

Login

user name

password

Figure 4 System login interface

3. Sample Preparation

Prepare the sample to be tested (refer to the relevant operation requirements for sample preparation), cell counting plates, 20 μ L range pipettor, and corresponding tips. Use the pipettor to draw 20 μ L of the prepared cell sample and add it evenly to the cell counting plate.

4. Experiment Test

- 1 Figure 5: On the "Experiment" screen of the display, click the icon of the type of experiment tested, such as "Trypan blue Viability".
- 2 Figure 6: Insert the cell counting plate into the sample port of the instrument, pay attention to the icon direction and hole order when inserting.

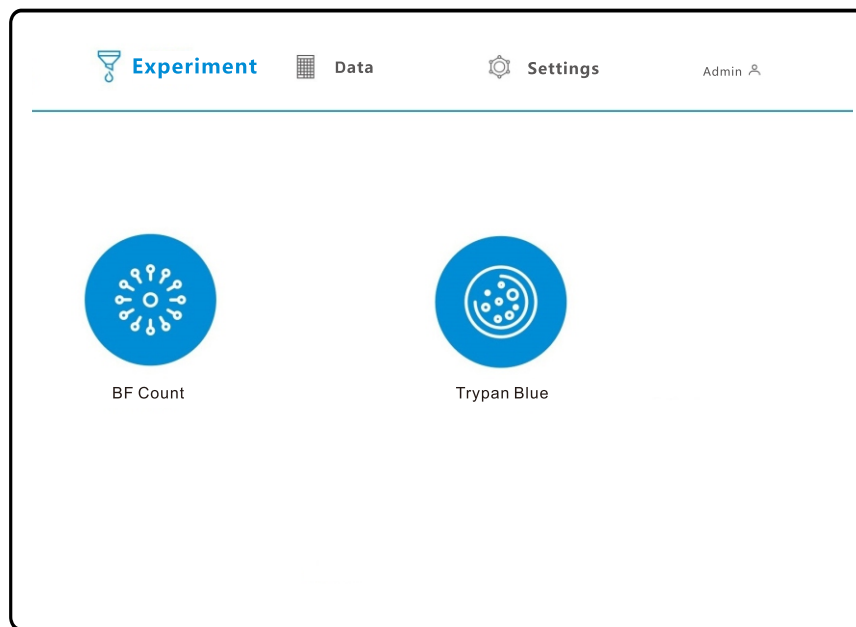

Figure 5 Experimental Type Interface

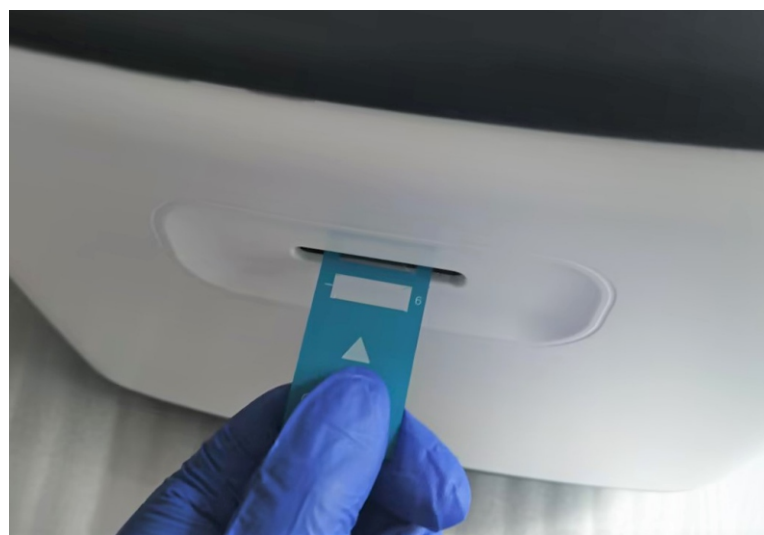
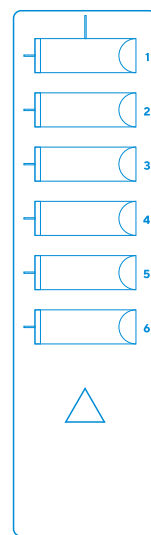

Figure 6 Cell counting plate injection port



- 3 Figure 7: Enter the experiment flow information, set as follows:

1. Enter the experiment name, select the cell type and dilution ratio.
2. Click on the desired hole positions (refer to Figure 6 for the correspondence between cell counting plate hole positions) in the system interface, selected hole positions turn yellow.
3. Click "Start", the instrument measures automatically.

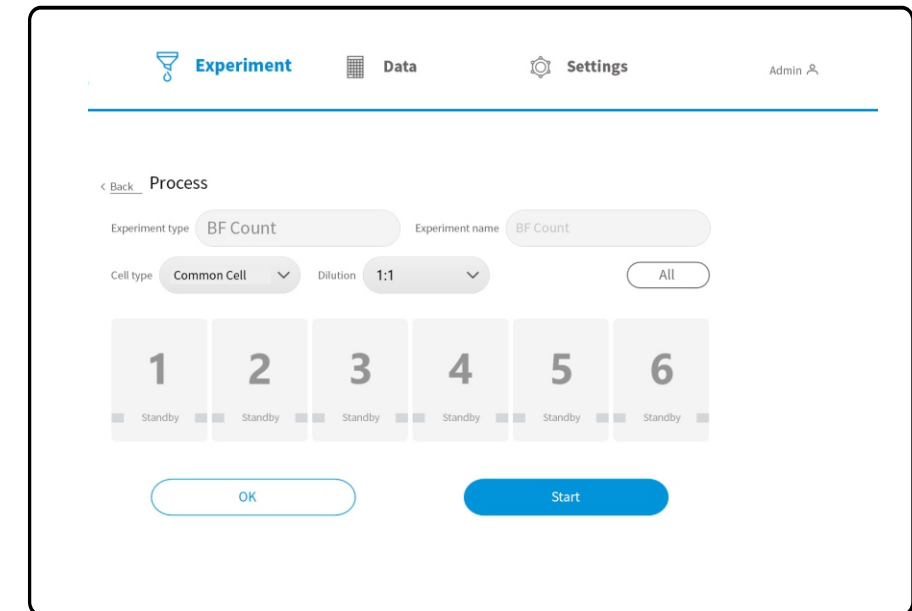

Figure 7 Experiment Information Entry Interface

- 4 Figure 8: Upon completion of the measurement, the cell counting plate will automatically exit, and the results will be displayed on the screen.

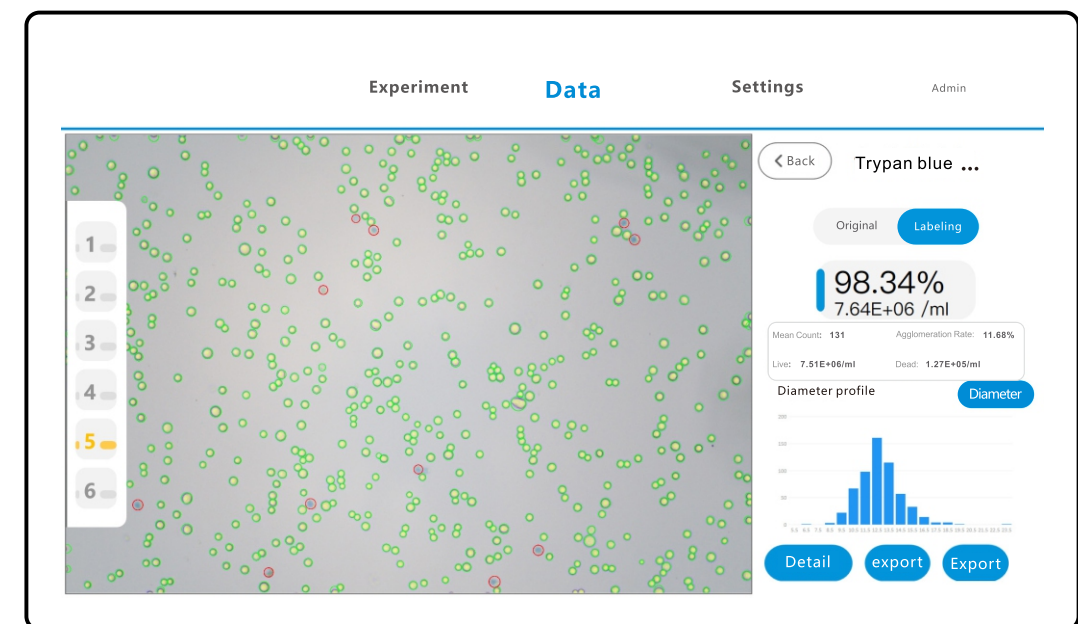

Figure 8 Result Display Interface

Click the button icons "Original", "Labeling" to view different channel test results and data.

Button Name	Function Description
Details	View the detailed results of the current experiment and other field shooting pictures (default displays the second picture, three pictures /sample).
Report	View the PDF report of the current experiment.
Export	Export the shooting pictures, excel data, and PDF report of the current experiment, default export to USB drive. If server settings are required, please contact our company to set up.

5. Data Management

Figure 9: Taking "Trypan Blue Viability" as an example, click "Back" on the top right corner of the result interface (Figure 8) or directly click on the "Data" on the navigation bar above, and select "admin" in the experimenter drop-down menu, "Trypan Blue Viability" in the experiment type drop-down menu, to enter the "Trypan Blue Viability" data interface. Click to select the experiment records that need to be exported.

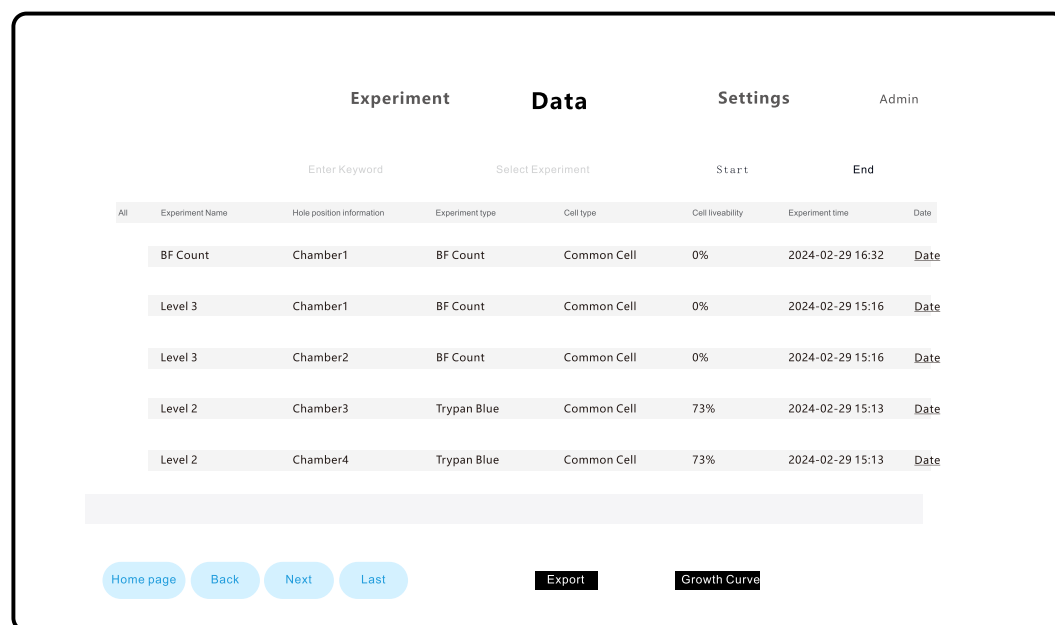

Figure 9: Data Interface

Button Name	Function Description
Data	View the detailed data of each field of the current experiment.
Growth Curve	A curve is automatically formed based on the selected data.
Export	Export the shooting pictures, excel data, and PDF report of the current experiment, default export to USB drive. If server settings are required, please contact Ningbo Lixian Intelligent Technology to set up, multiple selections are available for this export.
Delete	Delete the selected data.

⚠ Note: In the export interface of the screen, the option of the USB disk changes from gray unselectable to blue optional state, indicating that data transmission is available.

6. Shut Down the Instrument

After the experiment test is completed, press the main switch on the front of the device, the screen will turn off. Then press the power switch at the back of the device to the "off" position. Lastly, unplug the power cord.

⚠ Note: Please remove the cell counting plate before shutting down.

Common Questions (Q&A)

Q:How many volumes of samples should be added each time?

A:20uL of sample should be added to each well.

Q: How accurate is the counting of the instrument? Will it be affected by factors such as sufficient resuspension and concentration?

A: The software of the instrument adopts a combination of reinforcement learning semantic segmentation algorithm and traditional graphic image algorithm to address issues of uneven cell features and cell clustering in different environments, ensuring the effectiveness of experimental data results.

Q: How does the instrument distinguish and recognize live cells, dead cells, celimpurities, and fragments?

A: Using AI + feature intelligent algorithm, it automatically clusters and recognizes different cells and materials.

Q:How long does it take for the instrument complete to account test?

A: Accurate counting can be completed within 8 seconds for a single well with Trypan Blue.

Q:Can the instrument use other brands of celcounting plates? Can they be reused?

A: To ensure experimental effects, it is necessary to use the disposable cell counting plates provided by our company.

Q: Will the experiment data be automatically saved? How is the experiment data exported?

A: The experiment data will be automatically saved in the computer host's database and disk of the equipment, The export interface of the instrument experiment results can export experiment data.

Q:Will the software of the instrument be updated automatically? How to update?

A:The software cannot be updated automatically.